

Saddles for Twinwall Pipe

- No adhesives, sealant or concrete required
- Eliminates need to pre-order a factory made junction
- For use on new or existing drainage systems
- Reduces material and labour costs
- Increases positioning flexibility
- Can be combined with a product 'add-on' to connect different size laterals
- Small and lightweight, easy to transport and handle for quick installation
- Installation unaffected by weather conditions
- Robust and should not be damaged under normal site conditions
- WRc Approved™



Fernco's range of saddles for Twinwall pipes are an approved and more flexible option than pipe junctions when connecting lateral (or branch) pipes into main drain pipelines. The saddles are ideal solutions and provide multiple benefits when used on new or existing drainage systems.

Fernco have designed a range of lateral connection saddle products specifically for Twinwall pipes to ensure the market has an 'off the shelf' solution for the most common connections. Fernco's range of Twinwall saddles ensure an airtight and watertight seal between a Twinwall pipe and a smaller lateral (or branch) pipe.

Saddles offer the same solution as pipe junctions, for example, lateral pipes from new build houses, road gullies etc need to be connected into the system mains. Both saddles and junctions offer this connection but with clear differences in the installation methods.

To ensure Fernco offers its customers piece of mind, all saddles for Twinwall pipes hold WRc Approval, a third party 'fitness-for-purpose' testing and accreditation body.

Junction method

Excavate around the entire external surface of the main pipeline.....Excavate a small top section of the main pipeline

Cut and remove an entire section of the pipeline.....Core a hole into the main pipeline

Using appropriate mechanical lifting equipment, lift out the old pipe and lift in and fit a new junction.....Connect a lightweight saddle into the cored hole



Main Benefits of using a saddle over a junction

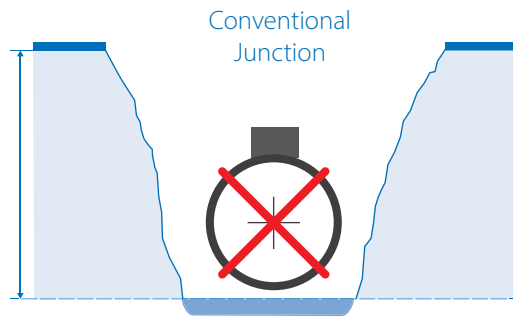
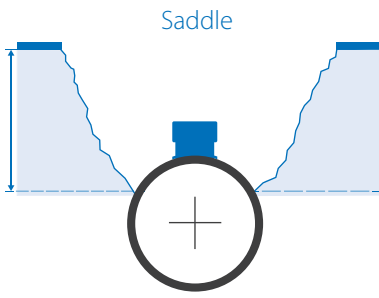

- Lower materials cost – the larger the pipes the greater the savings become
- Savings in labour time and cost
- Significantly reduced excavation requirements
- No heavy lifting equipment required
- Improved health & safety

Lateral Connection Saddle Variants



PA Saddle



UA Saddle

	PA Saddle	UA Saddle
Main Pipe Application	Plastic Structured Wall DN300-600	Plastic Structured Wall DN700 and above
Main Pipe Wall Thickness	To be advised on enquiry	25-125mm
Lateral Application	160mm PVC (Lateral Pipe Adaptors available to connect different sizes/materials)	All (Flexible coupling required to secure connection)
Lateral pipe deflection	Max: 8.5°	Max: 5°
WRc Cert Number	PT/426/0518	PT/425/0717

PA Saddle

For Twinwall DN300-600



Product Code	PAXXX
Description	Fernco PA Saddle Lateral Connection
Size	Main pipe: DN300-600 Lateral Pipe: 160mm PVC
Material	EPDM ABS plastic 1.4401 (316) Stainless Steel
Lateral Pipe Deflection	Max: 8.5°
Pressure Rating	0.5 bar / 7.25 psi
Vacuum	-0.3 bar
Vertical Load	10Kn / approx 1 tonne
Deformation	10%
Jetting Resistance	180 bar
Temperature Range	Max: 47°C
Standards	BS EN 681-1 BS EN 295-3 BS EN 295-4 WIS 4-35-01 WRc Approved™ - PT/426/0518
Main Pipe Requirements	
Pipe Size	DN300mm-600mm
Wall Thickness	Various
Drilled Hole Size	177mm (+2mm/-0.5mm)

i Quick Tip:

The PA Saddle will accept a 160mm PVC lateral pipe as standard, however, the saddle can be made universal by adding a Lateral Pipe Adaptor. The adaptor can be installed into the saddle which can branch off to fit a different material DN150 pipe or a smaller DN100 pipe.

Product Code	Lateral Pipe Size Suitability
PA110	Suitable for all DN100 pipes with an outside diameter between 110-122mm
PA130	Suitable for all DN100/DN125 pipes with an outside diameter between 121-136mm
PA140	Suitable for all DN100/DN125 pipes with an outside diameter between 130-145mm
PA170	Suitable for all DN150 pipes with an outside diameter between 161-175mm
PA180	Suitable for all DN150 pipes with an outside diameter between 170-192mm
PA200	Suitable for all DN150 pipes with an outside diameter between 190-215mm



UA Saddle

For Twinwall DN700 and above

DN150 inlet connectable with the use of a flexible coupling

Spacer rings interchanged by Fernco for specific applications

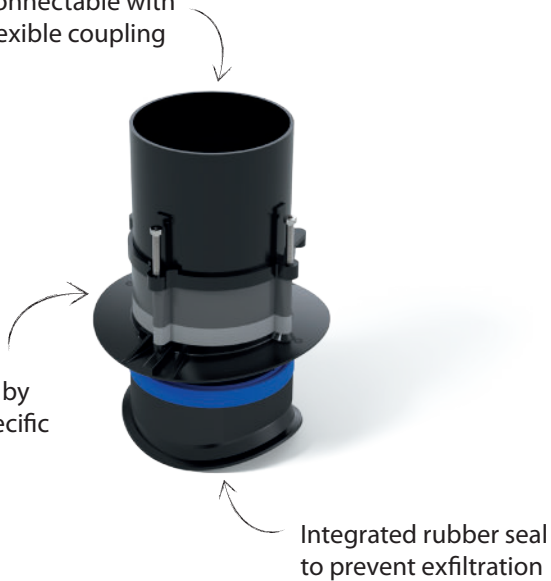

Product Code	UAXXX
Description	Fernco UA Saddle Lateral Connection
Size	Main pipe: DN700 and above Lateral Pipe: All (Flexible coupling required to secure connection)
Material	EPDM ABS plastic 1.4401 (316) Stainless Steel
Lateral Pipe Deflection	Max: 5°
Pressure Rating	0.5 bar / 7.25 psi
Vacuum	-0.3 bar
Vertical Load	10Kn / approx 1 tonne
Deformation	10%
Jetting Resistance	180 bar
Temperature Range	Max: 47°C
Standards	BS EN 681-1 BS EN 295-3 BS EN 295-4 WIS 4-35-01 WRc Approved™ - PT/425/0717
Main Pipe Requirements	
Pipe Size	DN700-3000
Wall Thickness	25-125mm
Drilled Hole Size	177mm (+2mm/-0.5mm)

Common couplings used to connect DN150 lateral pipes to the UA Saddle

Flexible Couplings Product Code	Lateral Pipe/Size Range	Example
AC1602	110-122mm	
AC1603	121-136mm	
SC165 / DC165	160mm	
SC175 / DC175	165-175mm	
AC1924	170-192mm	



Installation

The installation method for the PA saddle and the UA saddle is the same.

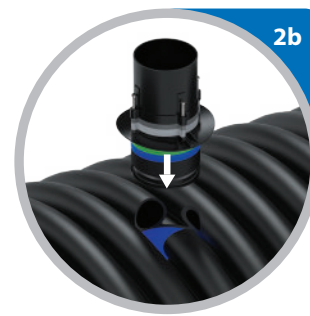
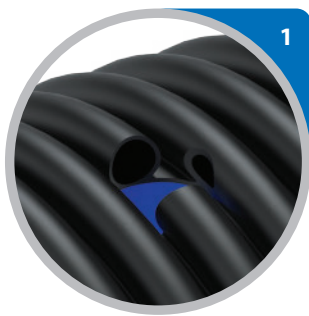

4 easy steps

1. Using a suitable holesaw, core a hole of 177mm (+2mm/-0.5mm) diameter in the wall of the pipe into which the saddle is to be fitted. It is important that the hole is perpendicular to the pipe and that the holesaw is long enough to cut through the wall in one pass (1). Remove any burring or flashing from the edges of the hole by using a de-burring tool and wipe the inside surface clean. Apply lubricant to the outer face of the inner sleeve and seal of the saddle.
2. Insert the saddle into the hole so that the saddle flange sits snugly onto the pipe. (2a/2b).
3. Using a 'T' handled 6mm hexagon tool, turn screws in a clockwise direction alternately by approximately 5 rotations at a time (3). Continue turning the screws until the underside of the head touches the face of the bolt ring.
4. Connect the lateral pipe to the PA Saddle by pushing 160mm PVC into the saddle inlet (4a), or connect lateral pipe to UA Saddle using a suitable flexible coupling (4b).

Note: It is important that the core hole is perpendicular to the pipe.

General Information

Quality, Standards and Approvals

Certified by the British Standards Institution (BSI) as a company of assessed capability, with a quality management system which meets the requirements of BS EN ISO 9001:2015

Fernco are the leaders in wastewater connection innovation; utilising the most advanced methods and techniques for precision-manufactured products, all of which comply with or exceed relevant British and European standards to ensure reliability and sustainability.

Our saddles for twin wall pipes (PA and UA saddles) hold WRc Approved™ status.



The WRc Approved™ scheme is recognised and established within the construction industry; providing suppliers, buyers and end-users confidence that the products are fit for purpose. The scheme reduces risks in procurement by ensuring quality, performance and installation processes have been tested with the most stringent of requirements, in conformance with BS EN 295 and BS EN 16397.

Fernco can offer a range of Twinwall lateral connection products which carry the assurance of WRc approval. Saddles, when compared with factory made junctions, can offer a multitude of benefits both in procurement and on-site in areas such as H&S, labour, installation time, flexibility and cost.

Environment

Operating Environmental Management Systems which are certified to ISO 14001: 2015.

Supply

All Fernco products are supplied through a national and global network of distribution and merchant partners. For stockist details, contact Fernco.

Technical Support

Fernco have a team of product experts on hand to support all customers with technical support and advice.

Contact Fernco Technical Department:

Tel: +61 (0) 2 9450 0766

Email: technical@fernco.com.au

Enquiries

Sales:

Tel: +61 (0) 2 9450 0766

Email: sales@fernco.com.au